



PROXSECURE UHF LABELS PVT. LTD.

# PID-4519

PID- 4 5 1 9 Labels were specially designed for apparel and item-level retail applications. It can be applied to a wide range of non-metallic objects, making it suitable for various other applications like warehouse management, asset tracking, inventory management, box level tagging, etc.

It performs well on various non-metallic objects, including plastic or cardboard cases & glass surface making it ideal for retails & multiple industrial applications.

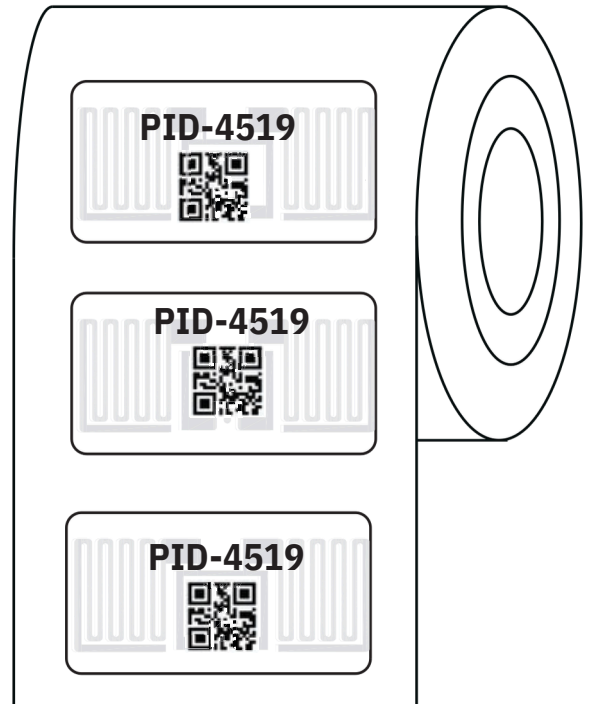

## Applications



Asset Management



Retail Management



Warehouse Management

## Order Information

Part Number	IC Type	Memory Configuration
RFL-160201 - RFL- (Polyster) 160202 - GLOBAL (Paper)	Impinj Monza M730	EPC Memory - 128 bits
RFL- 160501 - GLOBAL (Polyster) RFL- 160502 - GLOBAL (Paper)	NXP Ucode 9	EPC Memory - 96 bits

## Electrical Specifications

Operational Frequency	FCC: 902-928MHz ETSI: 865- 868 MHz
Interface Protocol	ISO 18000-63 and EPCglobal Gen2v2
Chip Type*	Impinj Monza M730
Memory Configuration	EPC Memory - 128 bits
Data Retention	10 Years
Write Cycle Endurance	100,000 cycles
Read Range**	upto 10.5 Meter

## Product Characteristics

Die Cut Size	45.0 X 19.0 mm / 1.77 X 0.74 in
Antenna size	42.0 X 16.0 mm / 1.65 X 0.62 in
Front Material	Paper/Polyster
Packaging	Reel core inner dimension: 76.2mm/ 3" , 5000pcs/roll
Attachment	Adhesive
Yield	100 %

## Environmental Specifications

Operating Temperature	-30 to +80 °C
Storage Temperature	-30 to +80 °C
IP Rating	IP67

## Personalization

- Customer specific encoding of EPC.
- Customised printing of logo, text, barcode etc

## Product Drawing

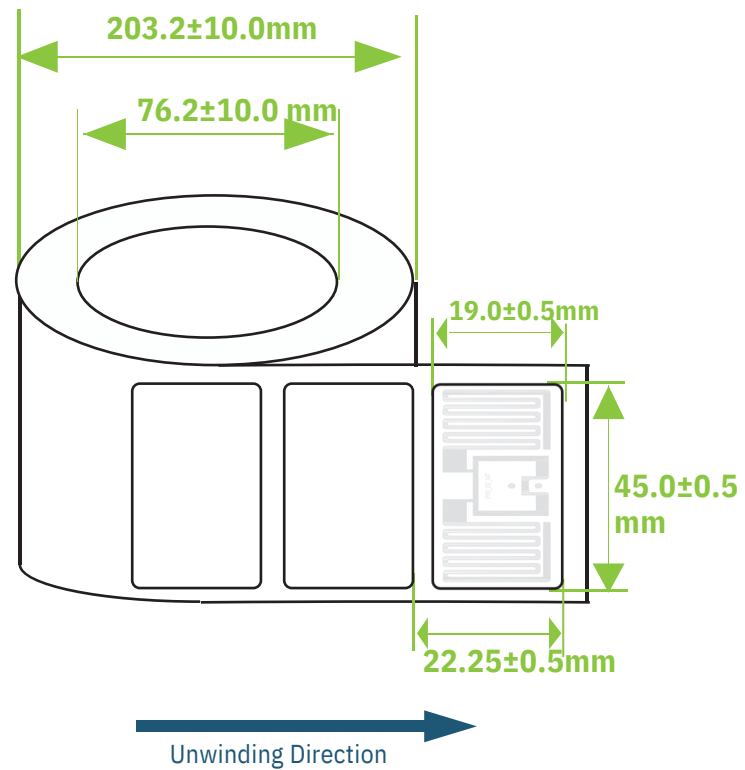

## READ RANGE GRAPH

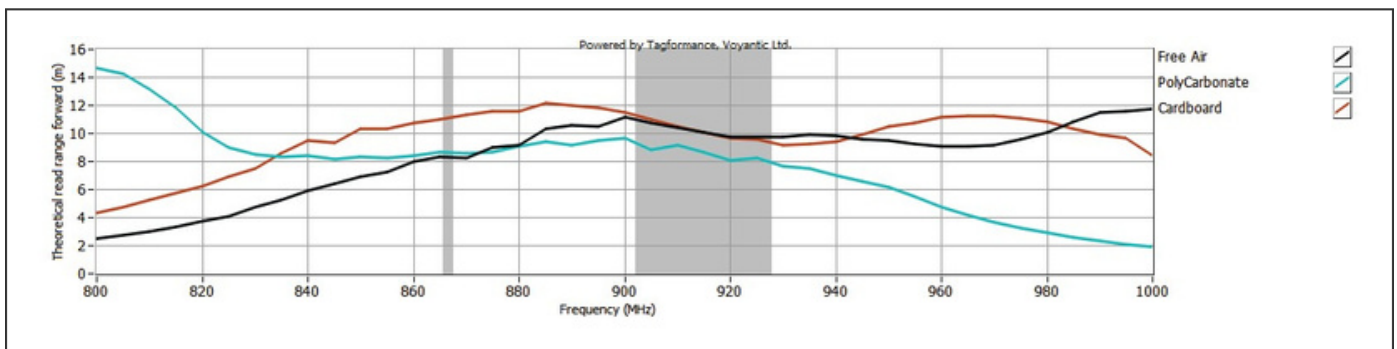

PID 4519 - RF performance(M730)

\*\* The indicated read range values are measured in our laboratory testing environment, where antennas with optimum directivity are used with maximum allowed operating power. Different surface materials and environments may exhibit different results.